

Class 150 Gate Valve

150SMBO
B.B.O.S.Y.
RF-flanged

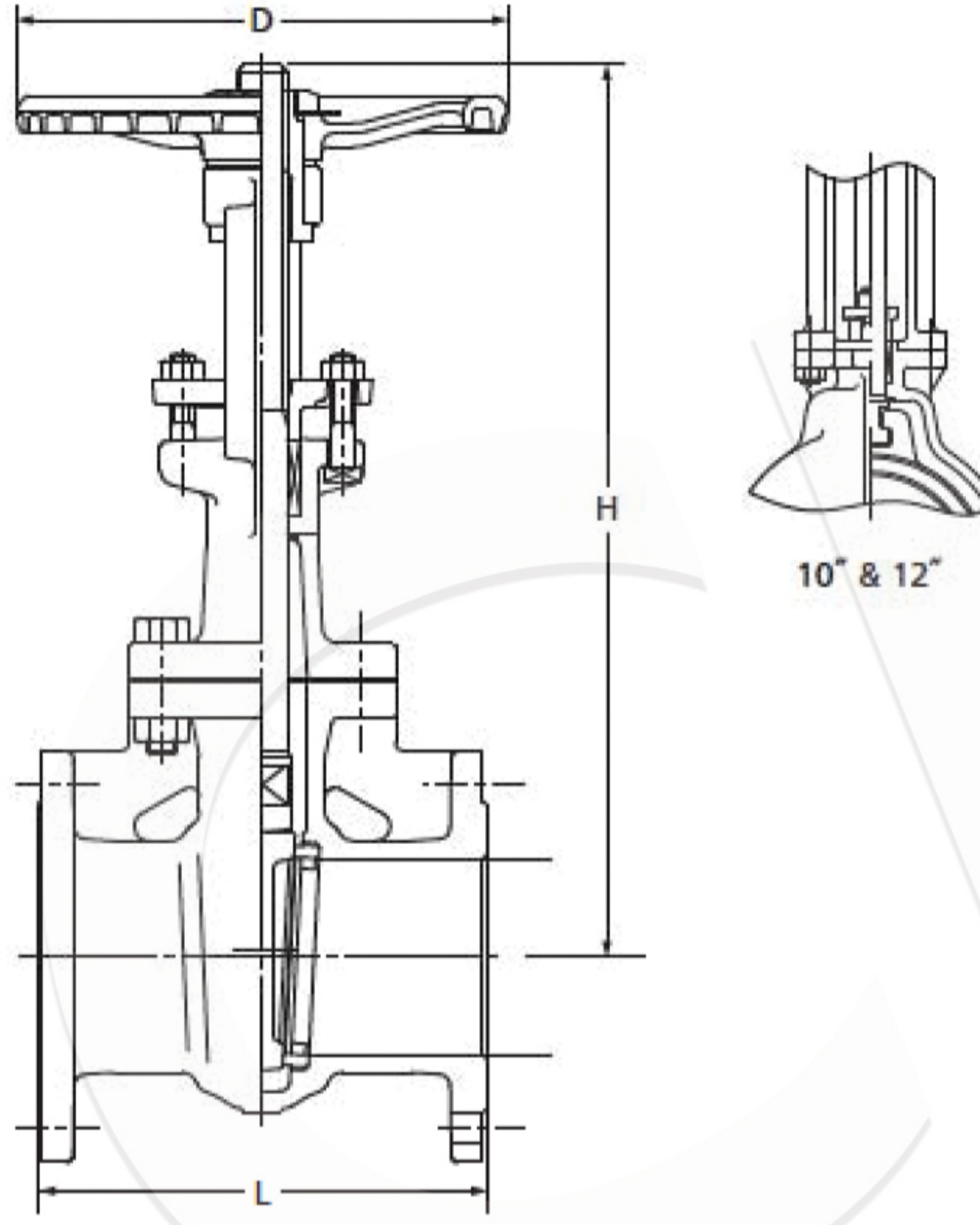

Face to face : ASME B16.10
End connection : ASME B16.5

−5°C ~ +38°C W.O.G. 1.73MPa
149°C W.O.G. 1.48MPa
260°C W.O.G. 1.18MPa
343°C W.O.G. 0.86MPa

● Use for lubricating or hydraulic oil is acceptable.

Materials

Parts	JIS material
Body	FCD-5
Bonnet	FCD-5
Stem	SUS403
Disc	SUS403 / SCS1 (1½" ~ 8") A105 + 13Cr (10") SCPH2 + 13Cr (12")
Gland	FCD-5
Gland packing	Non-asbestos Packing
Handwheel	FCD400
Gasket	Non-asbestos Sheet
Body seat ring	SUS403
Yoke sleeve	C6782BE (8" ~ 12" : CAC302)
Yoke	FCD-5

Dimensions

Size	mm										
	mm	40	50	65	80	100	125	150	200	250	300
	inch	1½	2	2½	3	4	5	6	8	10	12
L		165	178	190	203	229	254	267	292	330	356
H (open)		300	352	408	473	566	667	779	969	1181	1404
D		160	200	200	250	250	300	300	350	400	450

NOTE : For flange dimensions, refer to Page 45.